

- Required connections:**
- Power: 3x400V +N 32A-50Hz, with connector CEE-32A-5 P.  
The power outlet must be within 5 metres from the Yaskawa controller.
  - Air: Required air supply is 7 bar. One-touch fitting for hose Ø8mm.
  - Network: The RJ45 network cable has to reach the Yaskawa controller with more than 2 metres of overlength.

- Benodigde aansluitingen:**
- Voeding: 3x400V +Nul 32A-50Hz, aangesloten op stekker CEE-32A-5Polig.  
De voeding moet zich binnen 5 meter van de Yaskawa controller bevinden.
  - Lucht: De benodigde perslucht bedraagt 7bar. Insteeekoppeling voor slang Ø8mm.
  - Netwerk: De netwerkkabel moet bij de Yaskawa controller kunnen komen + 2m overlengte.

- Erforderliche Anschlüsse:**
- Leistung: 3x400V + Nullpunkt 32A-50Hz, auf 5-Poliger Stecker CEE-32A.  
Der Stromanschluss darf nicht weiter als 5 Meter von der Yaskawa-Controller entfernt sein.
  - Luft: Die erforderliche Luftzufuhr beträgt 7Bar. One-Touch-Fitting für Rohre Ø8mm.
  - Netzwerk: Das RJ45-Netzwerkkabel muss den Yaskawa-Controller mit einer Überlänge von mehr als 2 Metern erreichen.

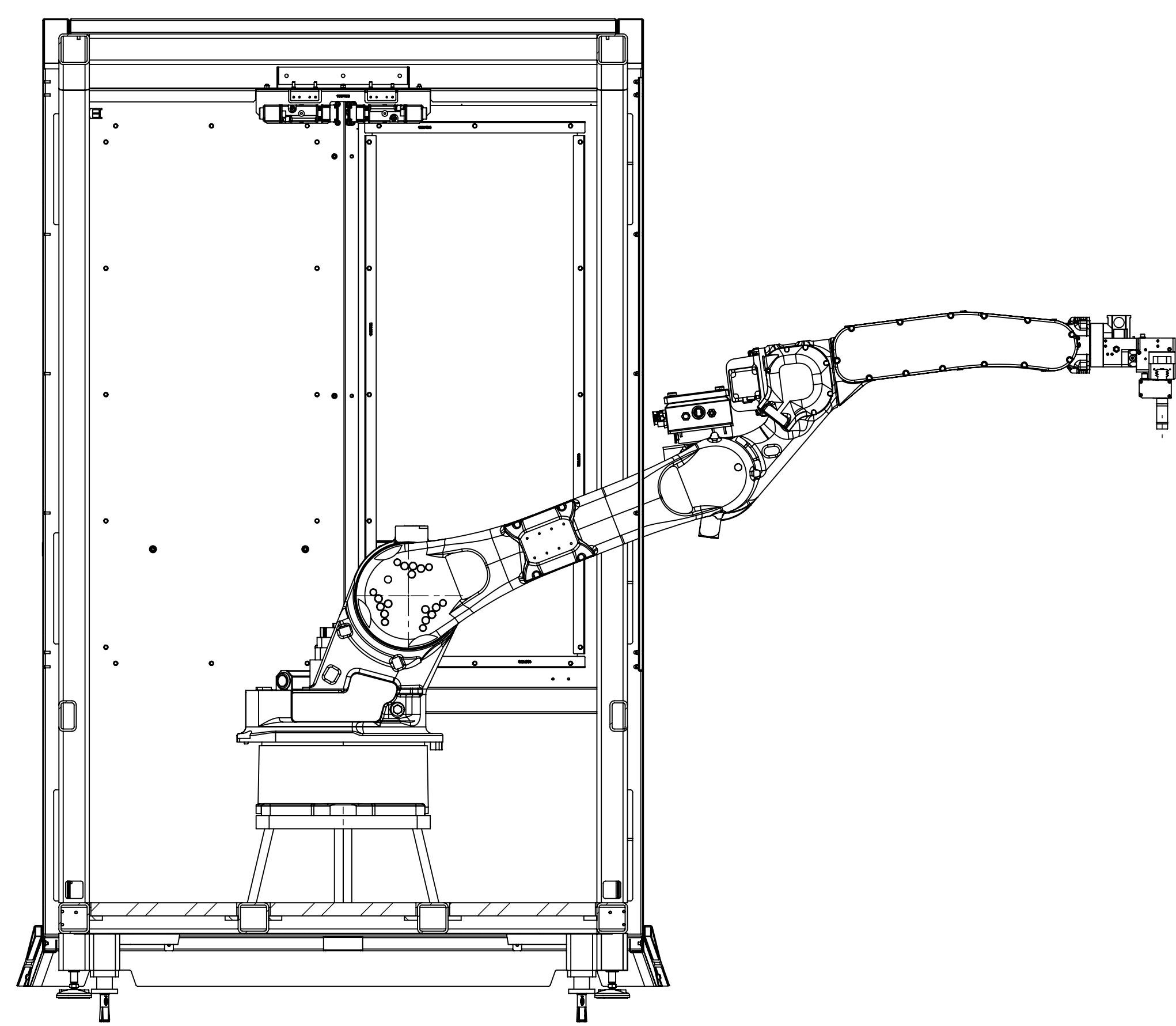

SECTION A-A

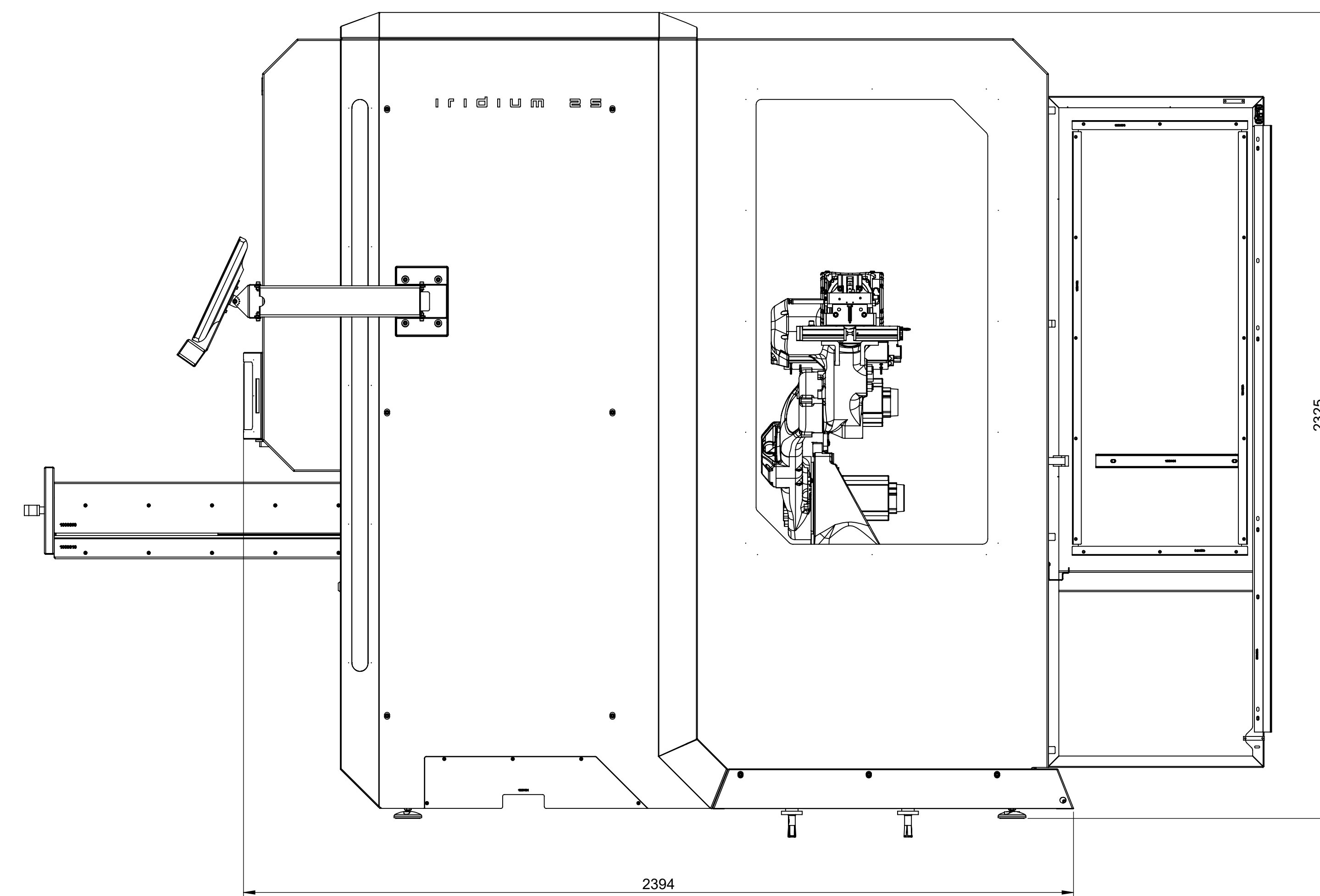

Description: Iridium25 Multibatch + pallet handling		Drawn: Admet.V.	Project:
Material: See month	Date: 30-11-2021	Author: zprzemski	
Treatment:	Scale: 1:10	Weight: 0.00 kg	Sheet No: 1/11
		BMO Automation P.O. Box 24 022 11 Wrocław The Netherlands T: +31 (0) 48 22437 B: +31 (0) 48 22437 www.bmoautomation.nl	
Universal compliance according RoHS Directive 2002/95/EC Restriction of Hazardous Substances according EN-60950-1:2005 EN-60950-1:2005		ISO 9001:2015 EN-ISO 1302 EN-ISO 1101	
Iridium 25 Multibatch + pallet handling			Revision: A0