

SECTION A-A

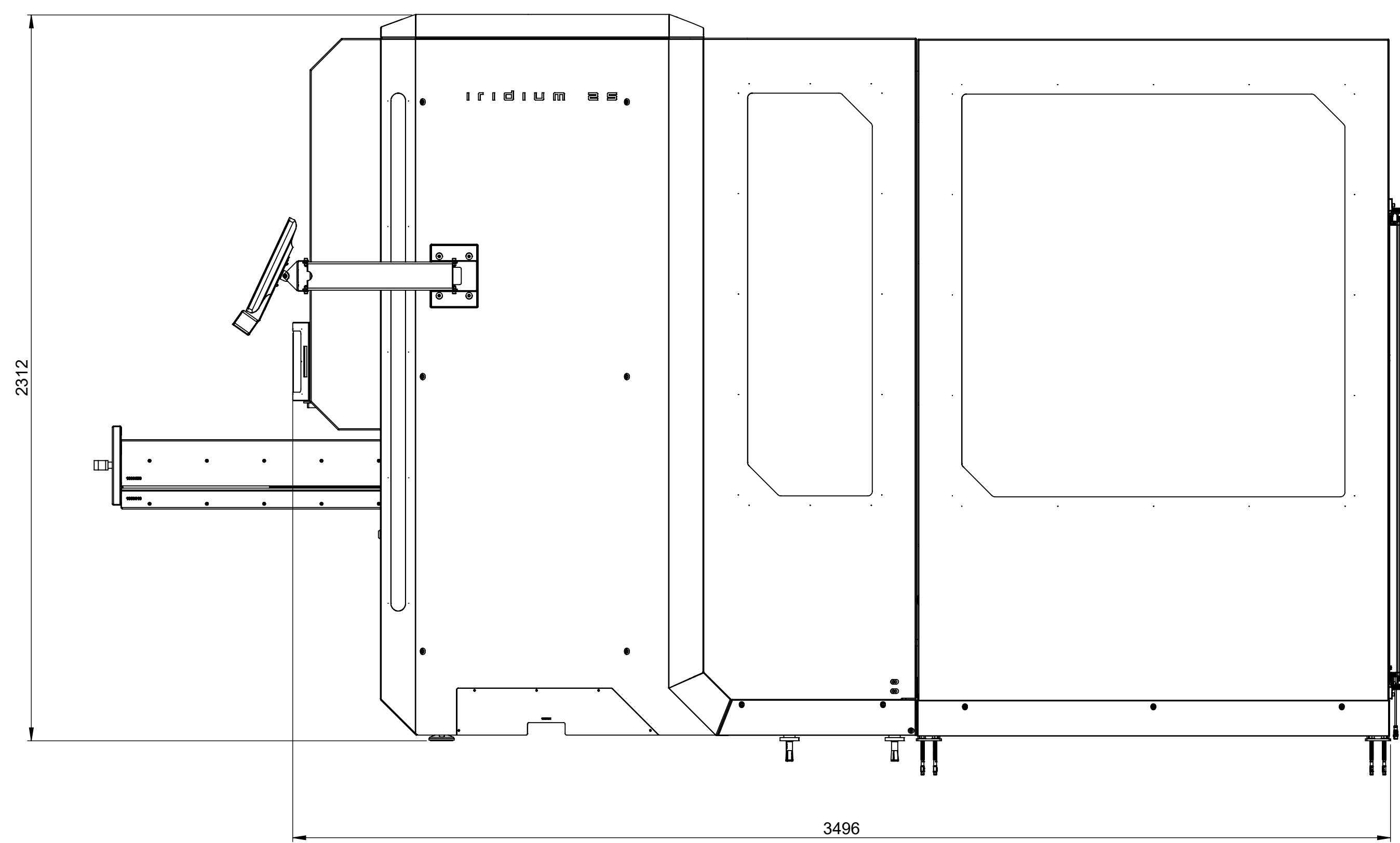
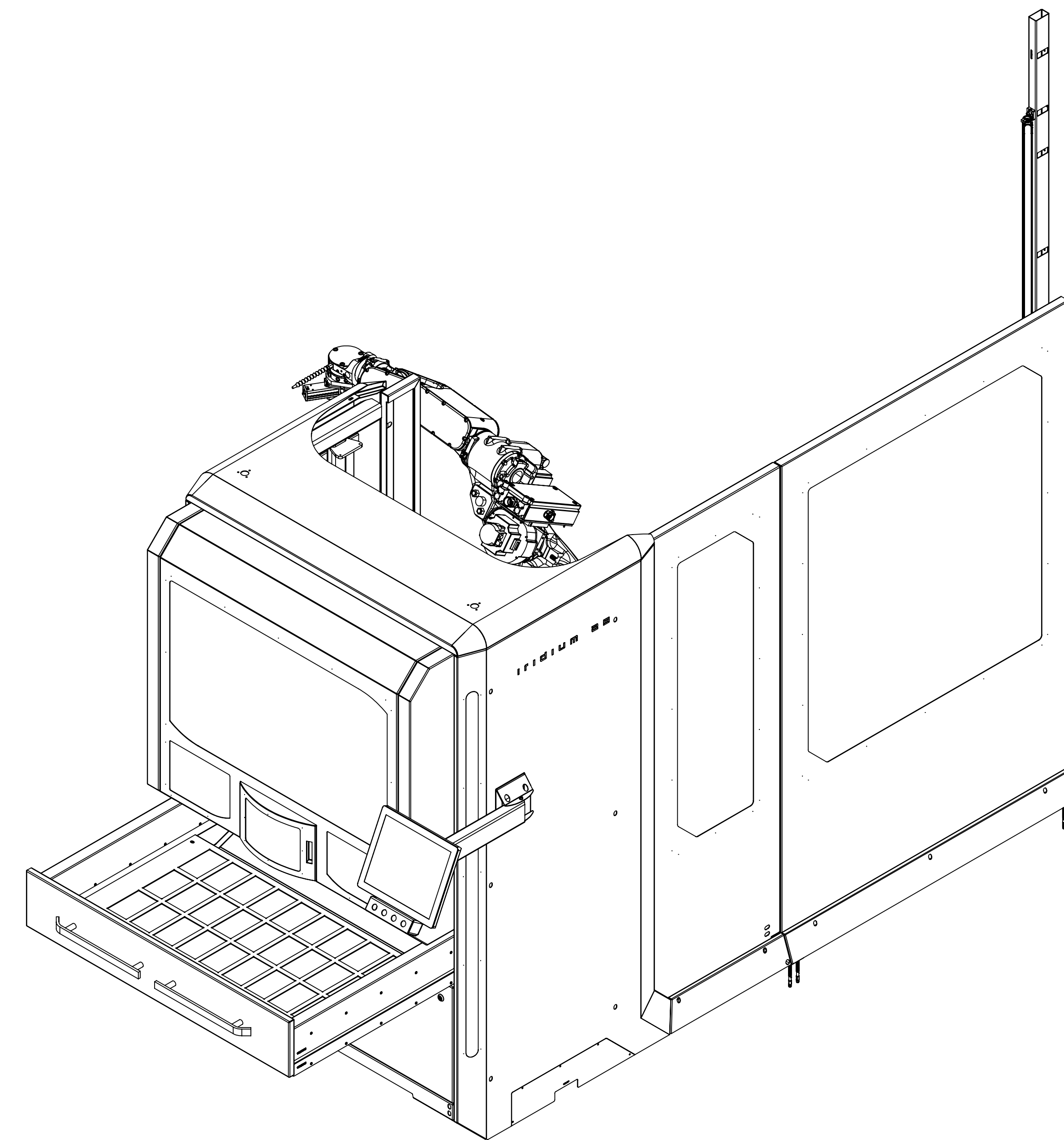

- Required connections:**
- Power: 3x400V +N 32A-50Hz, with connector CEE-32A-5 P. The power outlet must be within 5 metres from the Yaskawa controller.
 - Air: Required air supply is 7 bar. One-touch fitting for hose Ø8mm.
 - Network: The RJ45 network cable has to reach the Yaskawa controller with more than 2 metres of overlength.
- Benodigde aansluitingen:**
- Voeding: 3x400V +Nul 32A-50Hz, aangesloten op stecker CEE-32A-5Polig. De voeding moet zich binnen 5 meter van de Yaskawa controller bevinden.
 - Lucht: De benodigde perslucht bedraagt 7bar. Insteekkoppeling voor slang Ø8mm.
 - Netwerk: De netwerkkabel moet bij de Yaskawa controller kunnen komen + 2m overlengthe.
- Erforderliche Anschlüsse:**
- Leistung: 3x400V + Nullpunkt 32A-50Hz, auf 5-Poliger Stecker CEE-32A.
 - Der Stromanschluss darf nicht weiter als 5 Meter von der Yaskawa-Controller entfernt sein.
 - Luft: Die erforderliche Luftzufuhr beträgt 7Bar. One-Touch-Fitting für Rohre Ø8mm.
 - Netzwerk: Das RJ45-Netzwerkkabel muss den Yaskawa-Controller mit einer Überlänge von mehr als 2 Metern erreichen.

Description: Iridium 25 Frontloader Multibatch + pallet handling		Draw: S.V.	Project:
Material: See monch	Date: 1-12-2021	Author: [Signature]	Sheet: 1/1
Manufacturer: BMD Automation	Scale: 1:125	Weight: 0.00 kg	Revision: 0
		BMD Automation Progress according to the specifications of the customer.	
Iridium 25 Frontloader Multibatch + pallet handling		100 2788-006 EN-ISO 1101 EN-ISO 1101	