

- Required connections:**
- Power: 3x400V +N 32A-50Hz, with connector CEE-32A-5 P.  
The power outlet must be within 5 metres from the Yaskawa controller.
  - Air: Required air supply is 7 bar. One-touch fitting for hose Ø8mm.
  - Network: The RJ45 network cable has to reach the Yaskawa controller with more than 2 metres of overlength.
- Benodigde aansluitingen:**
- Voeding: 3x400V +Nul 32A-50Hz, aangesloten op stekker CEE-32A-5Polig.  
De voeding moet zich binnen 5 meter van de Yaskawa controller bevinden.
  - Lucht: De benodigde perslucht bedraagt 7bar. Insteeekoppeling voor slang Ø8mm.
  - Netwerk: De netwerkkabel moet bij de Yaskawa controller kunnen komen + 2m overlengte.
- Erforderliche Anschlüsse:**
- Leistung: 3x400V + Nullpunkt 32A-50Hz, auf 5-Poliger Stecker CEE-32A.  
Der Stromanschluss darf nicht weiter als 5 Meter von der Yaskawa-Controller entfernt sein.
  - Luft: Die erforderliche Luftzufuhr beträgt 7Bar. One-Touch-Fitting für Rohre Ø8mm.
  - Netzwerk: Das RJ45-Netzwerkkabel muss den Yaskawa-Controller mit einer Überlänge von mehr als 2 Metern erreichen.

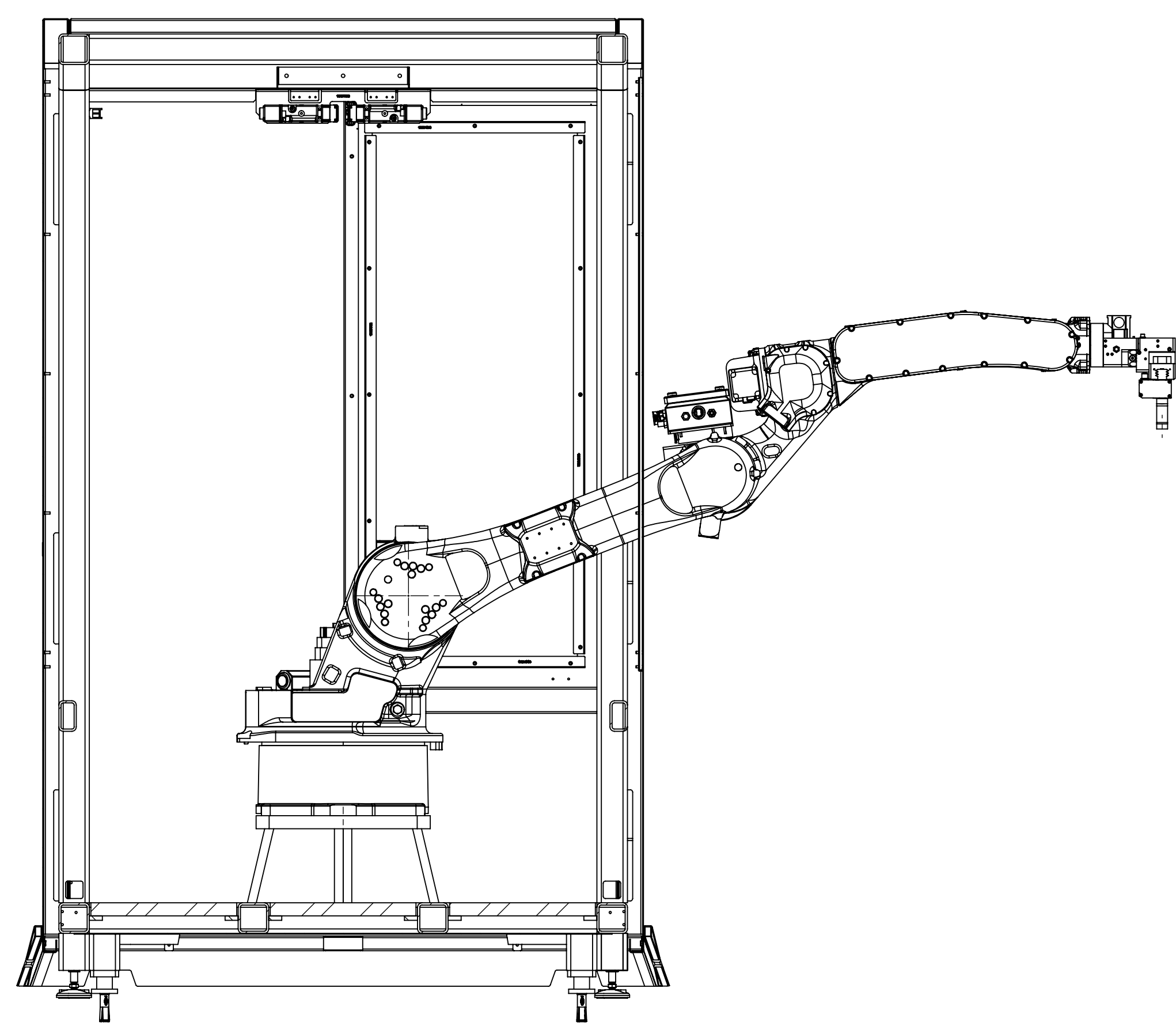

SECTION A-A

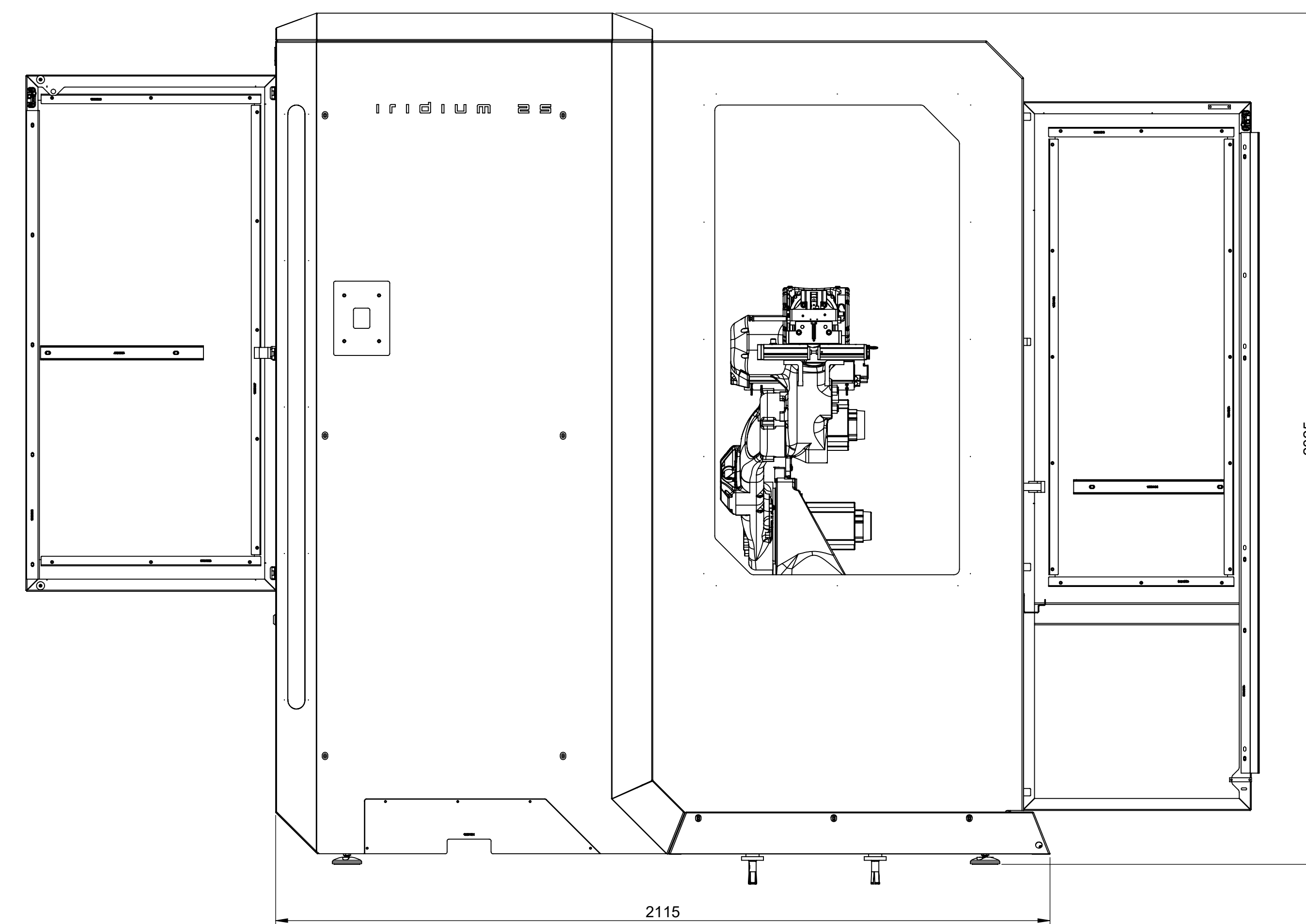

Description: Iridium 25		Drawn: S.V.	Project:
Date: 30-11-2021		Author: J. van der Vliet	Client: [Logo]
Material: See models	Scale: 1:10	Weight: 0.00 kg	Sheet No: 1/11
<p><b>BMO</b> AUTOMATION</p> <p>BMO Automation P.O. Box 24 1021 AA Amsterdam The Netherlands T: +31 (0) 20 481 2247 E: info@bmoautomation.nl www.bmoautomation.nl</p>		<p>Universal compliance according to EN ISO 13055 EN ISO 11010 EN ISO 11011</p>	<p>Revision: 0</p>