

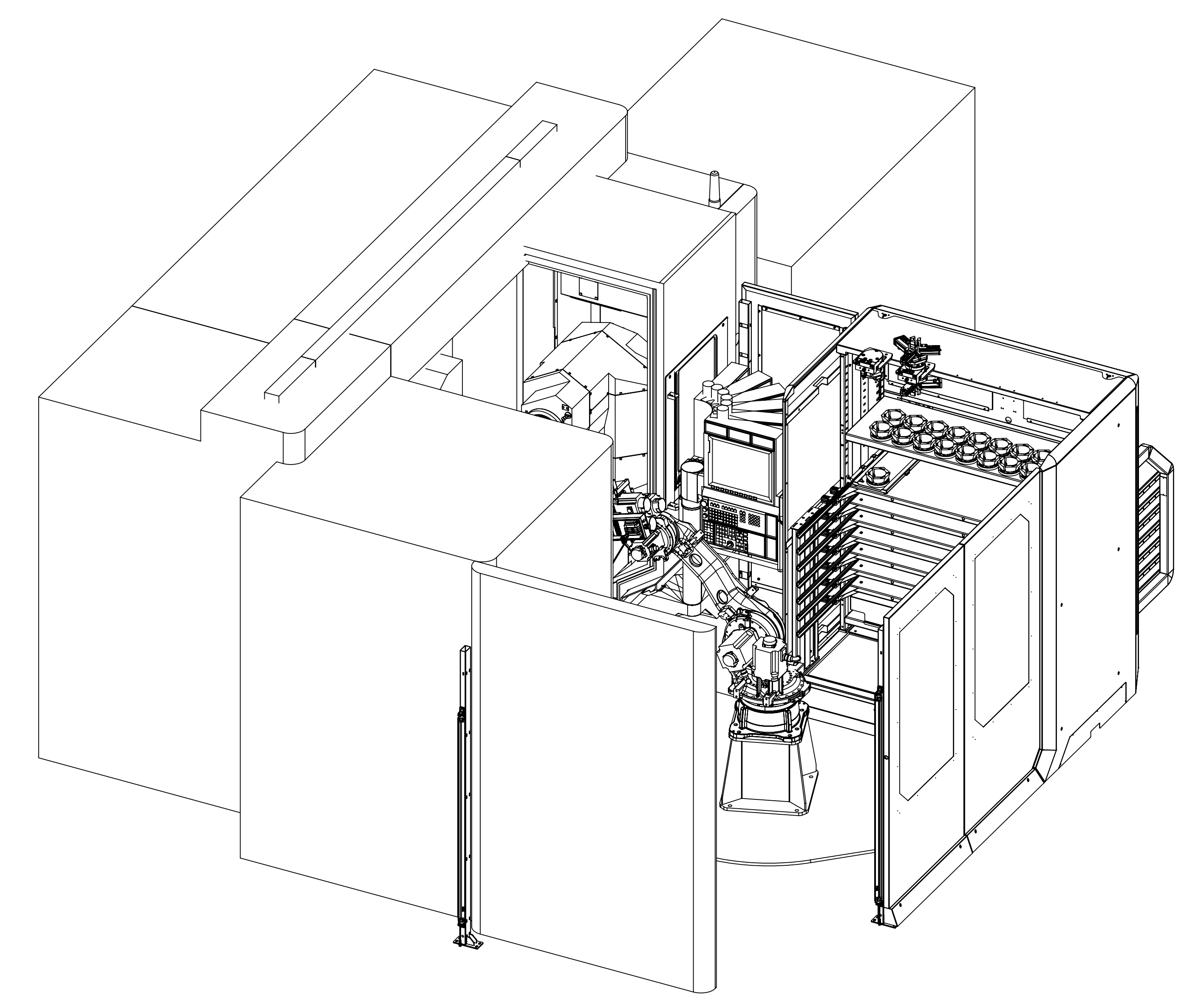

| REVISIONS |  |
|-----------|--|
|           |  |
|           |  |
|           |  |
|           |  |

- Benodigde aansluitingen:
- 380V 32A 5-polig nul aangesloten.
- Maximale afstand aansluiting t.o.v. DX200 controller = 5m.
- Perslucht 7bar. Insteekkoppeling voor slang rd8.
- Netwerkkabel. Deze moet bij de DX200 controller kunnen komen + 2mtr overlengte.

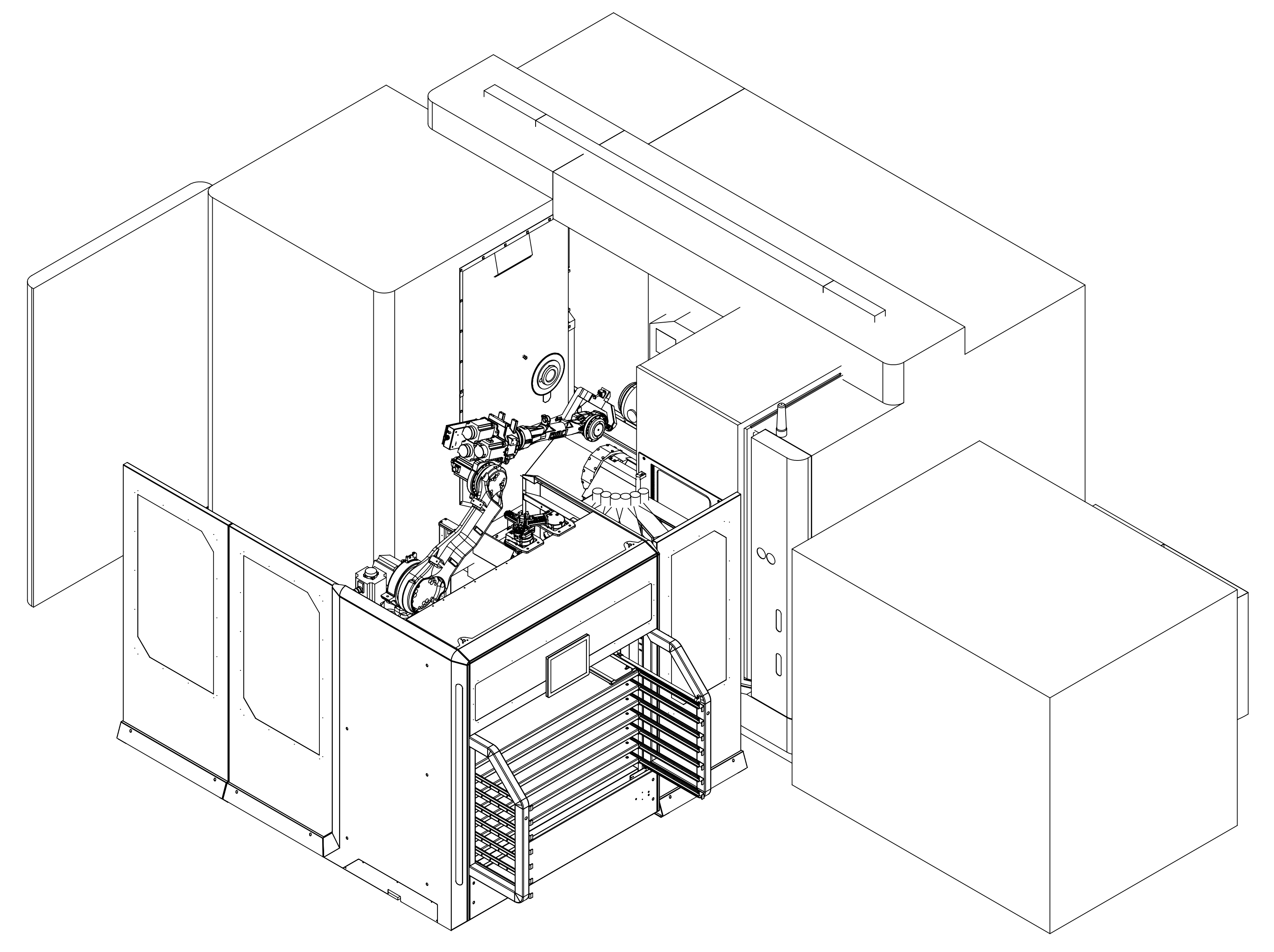
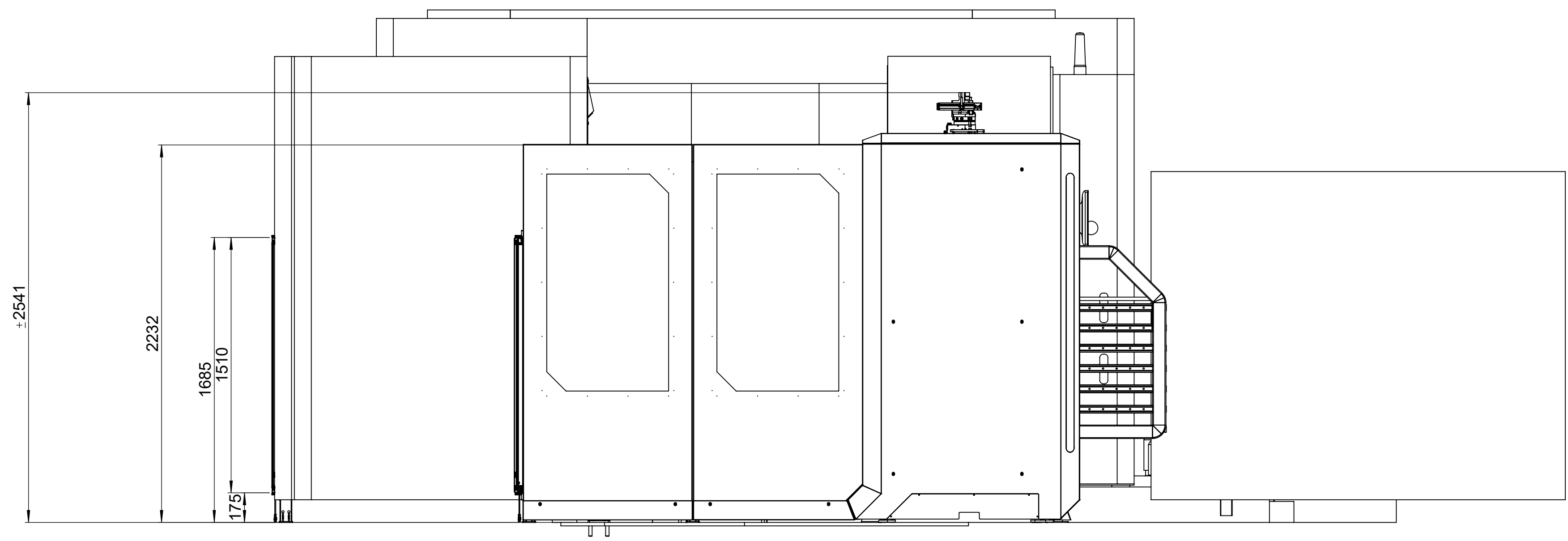
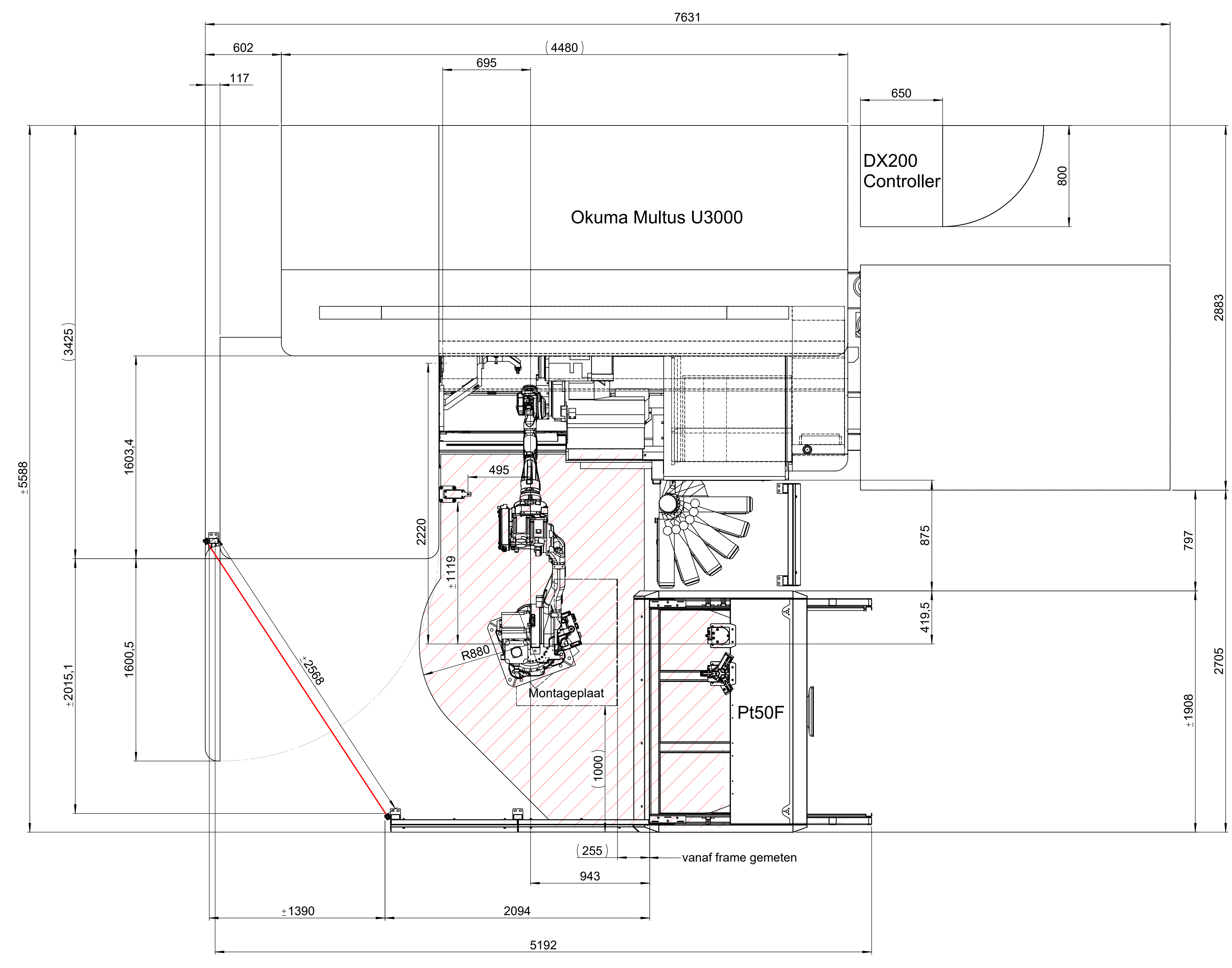

|   |  |                     |                  |
|---|--|---------------------|------------------|
| Description: Platinum 50 Frontloader - Okuma MULTUS U3000   |  | Drawn: R.C.         | Project:         |
| Date: 7-12-2018   |  | Drawn: Aronias      | Project: 1005034 |
| Material: See models  |  | Scale: 1:20         | Sheet No: 1/11   |
| Treatment:  |  | Weight: 0.00 kg     | Revision: 3      |
| <br><small>BMO Automation<br/>         Universale machines according to DIN EN ISO 1302<br/>         Roughness according to DIN EN ISO 1302<br/>         Conductor tolerances according to DIN EN ISO 1101</small> |  | Drawing No: 1005034 | Revision: 3      |