

Rev.	ZONE	Description	DATE	Approved
1		Sheet 2 toegevoegd voor installatie	28-8-2019	R.C.

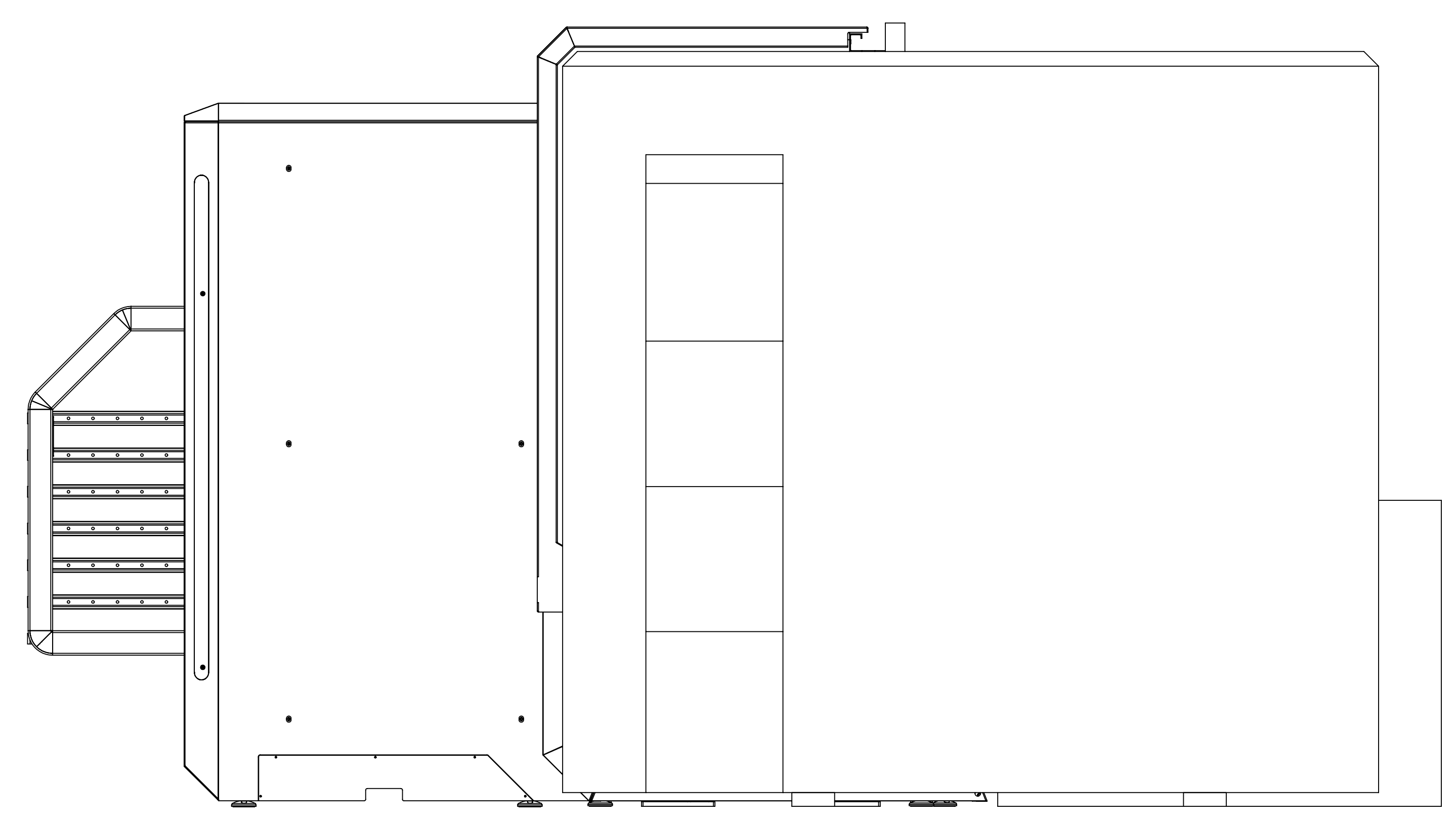
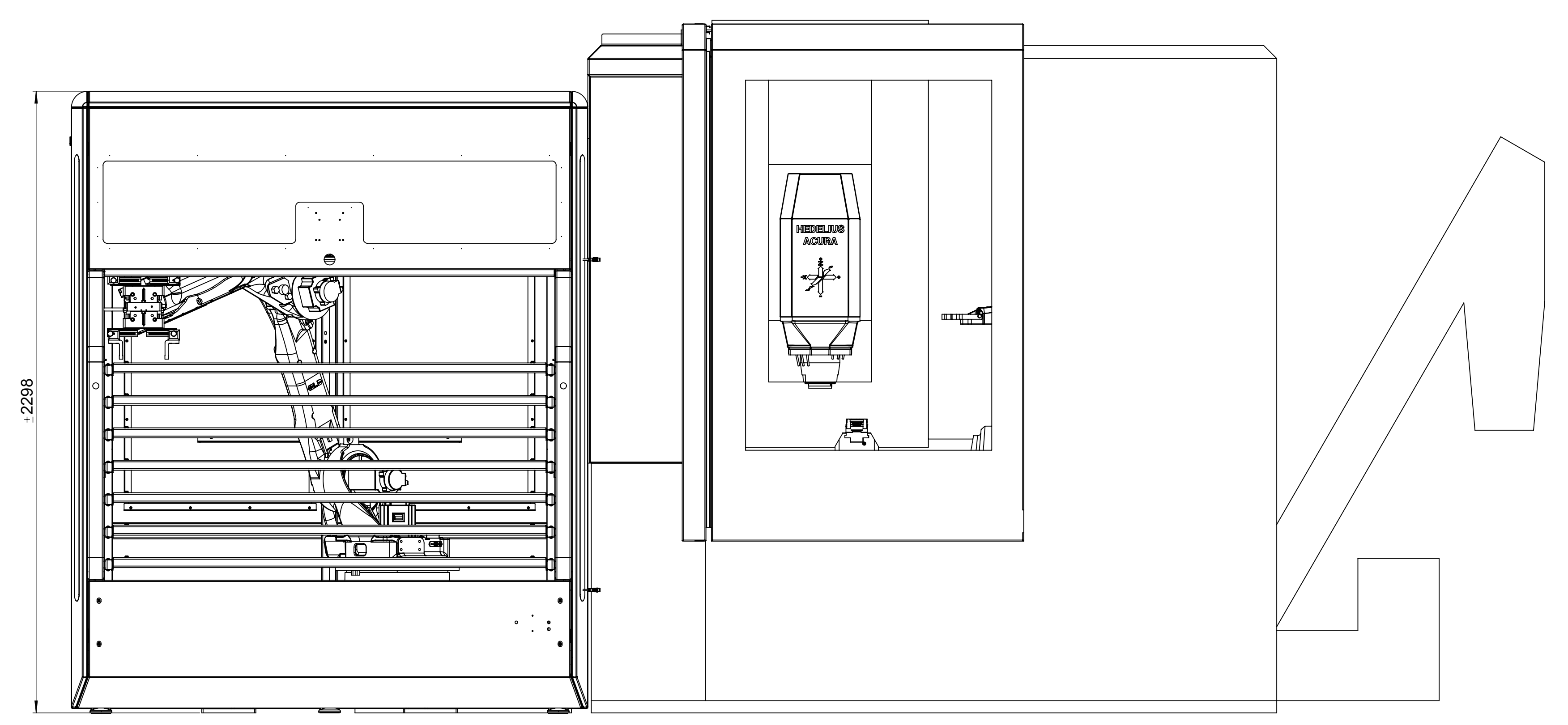
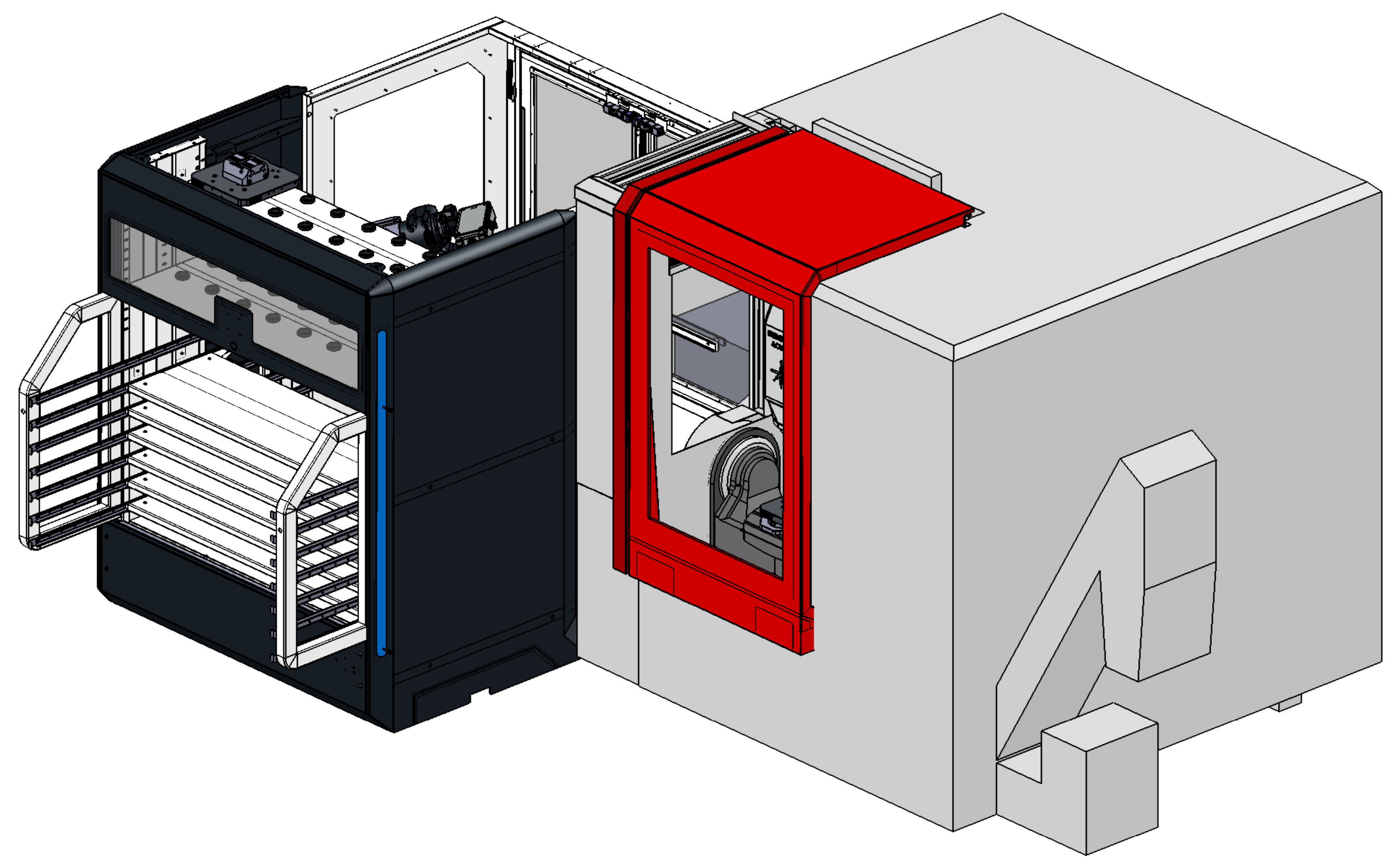
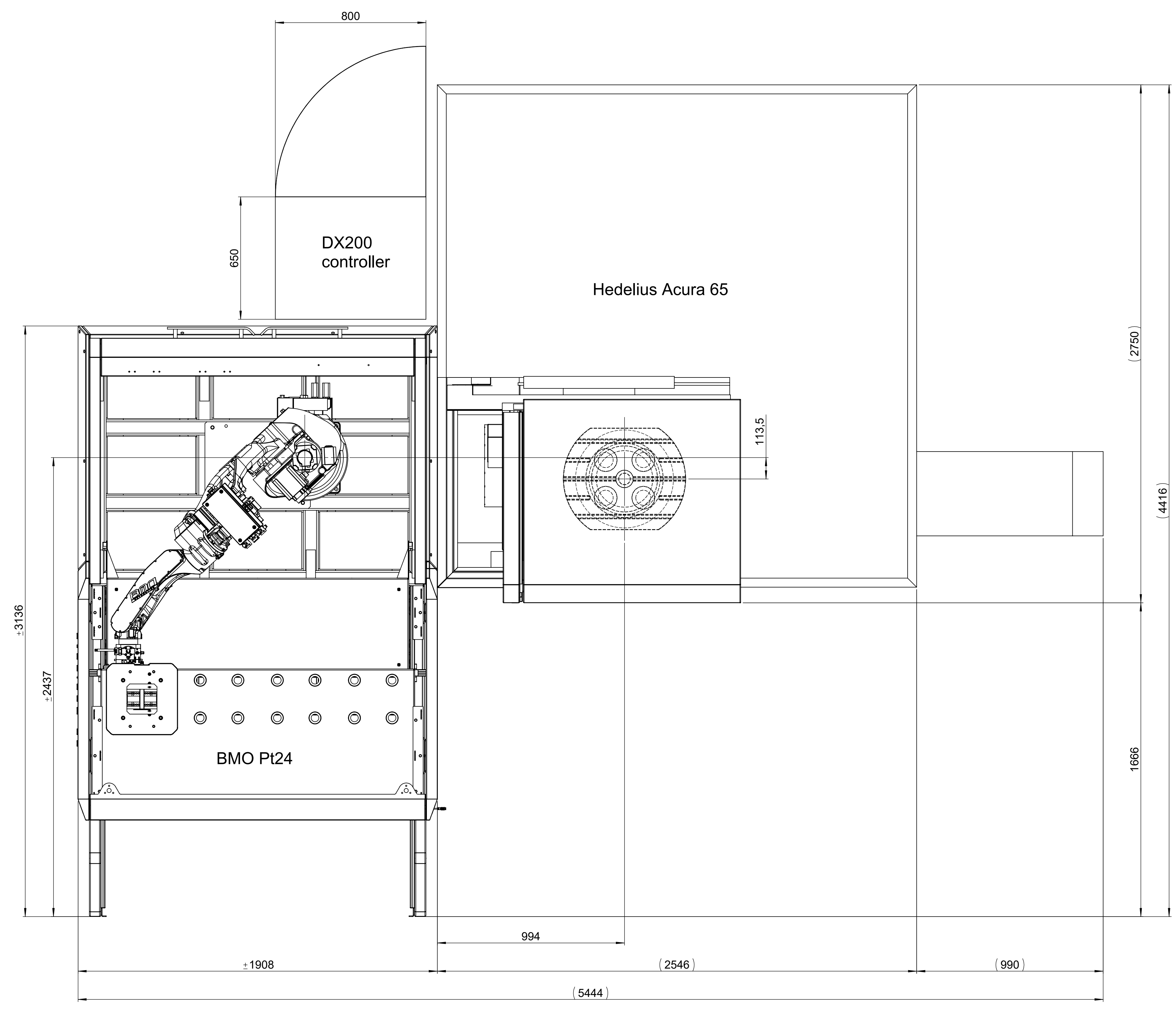

Description	Drawn	Project
Pt24 - Hedelius Acura 65	P.J.	American project
Material	See monch	Scale : 1:125
Treatment		Sheet No: 1/11
		180 2788-006 EN-ISO 1302 EN-ISO 1101
BMO Automation Magnanstraat 15 1027 XE Brussels Belgium T +32 (0) 474 82437 B info@bmoautomation.nl www.bmoautomation.nl		002 2788-006 EN-ISO 1302 EN-ISO 1101
Pt24 - Hedelius Acura 65		Revision 0